

Part number

CHPT 10.4 LS



Brief description:

surface mounting housings with single lever, size "57.27", metal cover, 1/2" NPT, metal version, IP66

Product description	
Version	metal version
Series	surface mounting housings with single lever
Product type	with 1 lever
Variant	metal cover
Family	CLASS enclosures
Size	size "57.27"
Technical data	
Material	metal
IP degree of protection	IP66 (and IP69K DIN 40050 - 9)
Cable entry	1/2" NPT
Further technical details	
Weight	297,00 g

Approvals / Standards	
Quality mark	UL (type:4/4X/12), CE, EAC
Conformity	CQC, CE
General ordering information	
EAN13 code	8015747114288
Tariff number	85369095
Packaging Information	
Packaging length	475,00 mm
Packaging height	170,00 mm
Packaging width	150,00 mm
Packaging weight	2,97 kg
Packaging volume	12,11 dm ³
Packaging description	Carton box
Packaging quantity	10 Pcs
Packaging EAN code	8015747114417
Sub-packaging weight	1,49 kg
Sub-packaging description	Plastic pakaging
Sub-packaging quantity	5 Pcs
Sub-packaging EAN barcode	8015747114424

Part number

CHPT 10.4 LS



Catalogue drawings

CHP L - CAP L MHP L - MAP L

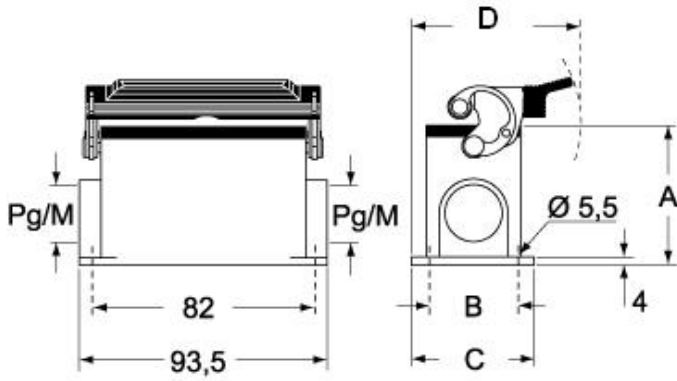

CHP LS - CAP LS MHP LS - MAP LS

